

# M12、M18

## AC/DC METAL FACE EXTENDED DISTANCE PROXIMITY SWITCH

M 12	
●	○
4 mm	8 mm
stainless steel	
●	

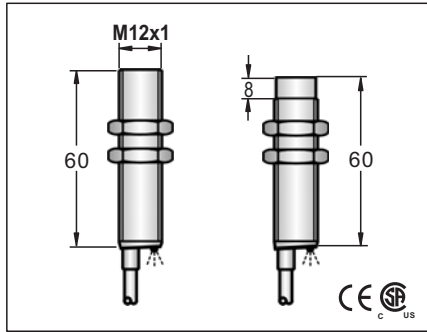

20-250 VAC, 50-60 Hz; 20-250 VDC	
DC RIPPLE <10%	
<2.5mA	
100mA	
<2.5mA	
2.2A for 20ms	
5mA	
<=10 VAC ; <=8 VDC	
25HZ AC; 40 Hz DC	
10ms/10ms	
<15%(Sr)	
<1.0% (Sr)	
IP67	
-25°C- +70°C	
<10% (Sr)	
YES(DC 20-30V ONLY)	
-	
-	
RFI>3V/m / EFT>1KV / ESD>4KV (contact)	
IEC 60947-5-2,Part 7.4.1 / IEC 60947-5-2,Part 7.4.2	
Stainless steel	

<u>ECS1-1204U-A3L2</u>	11	<u>ECS2-1208U-A3L2</u>	
<u>ECS1-1204U-B3L2</u>	12	<u>ECS2-1208U-B3L2</u>	

4 $\phi$ 3x0.15	
Approx.77g	Approx.76g

M 12	
●	○
4 mm	8 mm
stainless steel	
●	

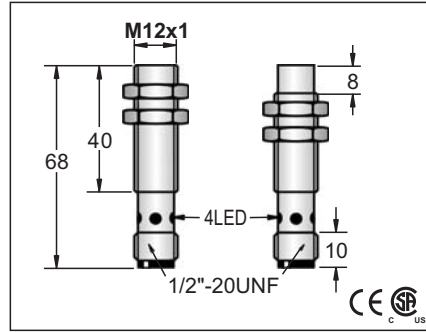

20-250 VAC, 50-60 Hz; 20-250 VDC	
DC RIPPLE <10%	
<2.5mA	
100mA	
<2.5mA	
2.2A for 20ms	
5mA	
<=10 VAC ; <=8 VDC	
25HZ AC; 40 Hz DC	
10ms/10ms	
<15%(Sr)	
<1.0% (Sr)	
IP67	
-25°C- +70°C	
<10% (Sr)	
YES(DC 20-30V ONLY)	
-	
-	
RFI>3V/m / EFT>1KV / ESD>4KV (contact)	
IEC 60947-5-2,Part 7.4.1 / IEC 60947-5-2,Part 7.4.2	
Stainless steel	

<u>ECS1-1204U-AUL3</u>	56	<u>ECS2-1208U-AUL3</u>	
<u>ECS1-1204U-BUL3</u>	56	<u>ECS2-1208U-BUL3</u>	

approx.30g		approx.29g	
------------	--	------------	--

M 18	
●	○
8 mm	16 mm
stainless steel	
●	

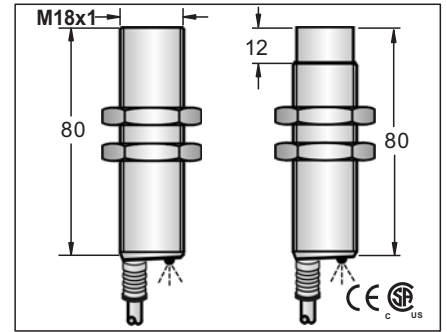

20-250 VAC, 50-60 Hz; 20-250 VDC	
DC RIPPLE <10%	
<2.5mA	
200mA	
<2.5mA	
2.2A for 20ms	
5mA	
<=10 VAC ; <=8 VDC	
25HZ AC; 40 Hz DC	
10ms/10ms	
<15%(Sr)	
<1.0% (Sr)	
IP67	
-25°C- +70°C	
<10% (Sr)	
YES	
-	
-	
RFI>3V/m / EFT>1KV / ESD>4KV (contact)	
IEC 60947-5-2,Part 7.4.1 / IEC 60947-5-2,Part 7.4.2	
Stainless steel	

<u>ECS1-1808U-A3L2</u>	11	<u>ECS2-1816U-A3L2</u>	
<u>ECS1-1808U-B3L2</u>	12	<u>ECS2-1816U-B3L2</u>	

5.0 $\phi$ 44x0.1	
approx.161g	approx.160g

Note:  
Coming Soon : Part numbers with underline

AC/DC METAL FACE  
EXTENDED DISTANCE PROXIMITY SWITCH

## AC/DC METAL FACE EXTENDED DISTANCE PROXIMITY SWITCH

M 18	
●	○
8 mm	16 mm
stainless steel	

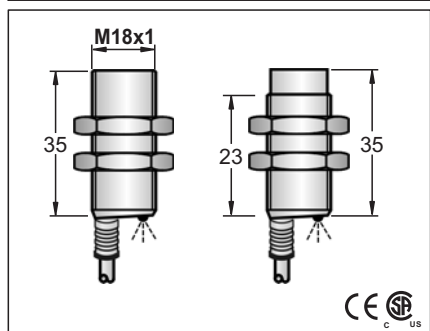

20-250 VAC, 50-60 Hz; 20-250 VDC
DC RIPPLE <10%
<2.5mA
200mA
<2.5mA
2.2A for 20ms
5mA
<=10 VAC :<=8 VDC
25HZ AC; 40 Hz DC
10ms/10ms
<15%(Sr)
<1.0% (Sr)
IP67
-25°C- + 70°C
<10% (Sr)
YES
-
RFI>3V/m / EFT>1KV / ESD>4KV (contact)
IEC 60947-5-2,Part 7.4.1 / IEC 60947-5-2,Part 7.4.2
Stainless steel

<u>ECS1-1808U-A3S2</u>	11	<u>ECS2-1816U-A3S2</u>
<u>ECS1-1808U-B3S2</u>	12	<u>ECS2-1816U-B3S2</u>

5.0 $\phi$ 44x0.1	
Approx.132 g	Approx.134 g

M 18	
●	○
8 mm	16 mm
stainless steel	

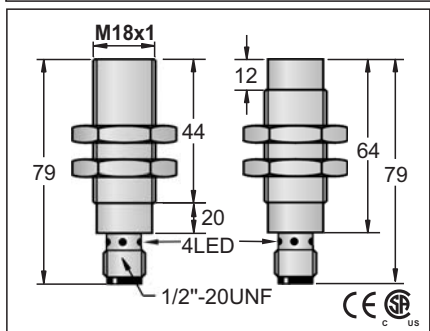

20-250 VAC, 50-60 Hz; 20-250 VDC
DC RIPPLE <10%
<2.5mA
200mA
<2.5mA
2.2A for 20ms
5mA
<=10 VAC :<=8 VDC
25HZ AC; 40 Hz DC
10ms/10ms
<15%(Sr)
<1.0% (Sr)
IP67
-25°C- + 70°C
<10% (Sr)
YES
-
RFI>3V/m / EFT>1KV / ESD>4KV (contact)
IEC 60947-5-2,Part 7.4.1 / IEC 60947-5-2,Part 7.4.2
Stainless steel

<u>ECS1-1808U-AUL3</u>	56	<u>ECS2-1816U-AUL3</u>
<u>ECS1-1808U-BUL3</u>	56	<u>ECS2-1816U-BUL3</u>

5.0 $\phi$ 44x0.1	
Approx.69 g	Approx.68 g

M 18	
●	○
8 mm	16 mm
stainless steel	

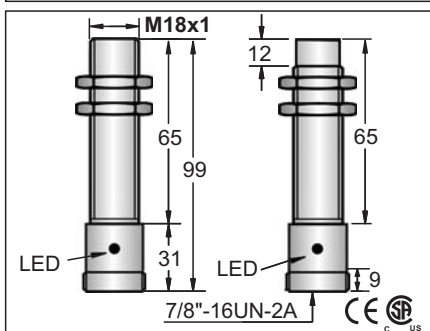

20-250 VAC, 50-60 Hz; 20-250 VDC
DC RIPPLE <10%
<2.5mA
200mA
<2.5mA
2.2A for 20ms
5mA
<=10 VAC :<=8 VDC
25HZ AC; 40 Hz DC
10ms/10ms
<15%(Sr)
<1.0% (Sr)
IP67
-25°C- + 70°C
<10% (Sr)
YES
-
RFI>3V/m / EFT>1KV / ESD>4KV (contact)
IEC 60947-5-2,Part 7.4.1 / IEC 60947-5-2,Part 7.4.2
Stainless steel

<u>ECS1-1808U-AZL3</u>	65	<u>ECS2-1816U-AZL3</u>
<u>ECS1-1808U-BZL3</u>	65	<u>ECS2-1816U-BZL3</u>

5.0 $\phi$ 44x0.1	
Approx.94 g	Approx.91 g

Note:  
Coming Soon : Part numbers with underline

AC/DC METAL FACE  
EXTENDED DISTANCE PROXIMITY SWITCH

## AC/DC METAL FACE EXTENDED DISTANCE PROXIMITY SWITCH

M 30	
●	○
16 mm	25mm
stainless steel	
●	

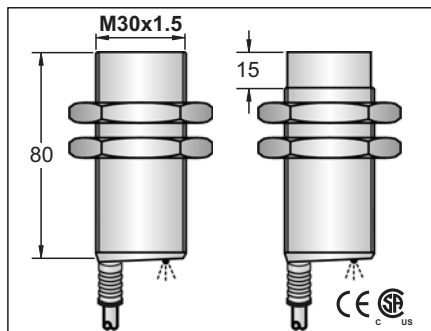

20-250 VAC, 50-60 Hz; 20-250 VDC
DC RIPPLE <10%
<2.5mA
200mA
<2.5mA
2.2A for 20ms
5mA
<=10 VAC : <=8 VDC
25HZ AC; 40 Hz DC
10ms/10ms
<15%(Sr)
<1.0% (Sr)
IP67
-25°C - +70°C
<10% (Sr)
YES
-
-
RFI>3V/m / EFT>1KV / ESD>4KV (contact)
IEC 60947-5-2,Part 7.4.1 / IEC 60947-5-2,Part 7.4.2
Stainless steel

EGS1-3016U-A3L2	11	EGS2-3025U-A3L2
EGS1-3016U-B3L2	12	EGS2-3025U-B3L2

5.8 φ3x0.5	
approx.247g	approx.237g

M 30	
●	○
16 mm	25 mm
stainless steel	
●	

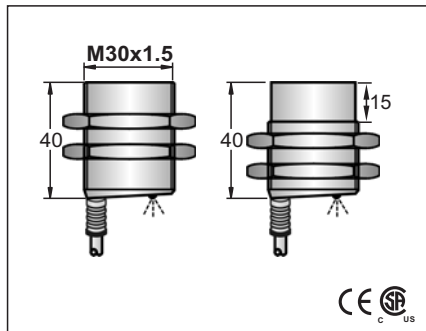

20-250 VAC, 50-60 Hz; 20-250 VDC
DC RIPPLE <10%
<2.5mA
200mA
<2.5mA
2.2A for 20ms
5mA
<=10 VAC : <=8 VDC
25HZ AC; 40 Hz DC
10ms/10ms
<15%(Sr)
<1.0% (Sr)
IP67
-25°C - +70°C
<10% (Sr)
YES
-
-
RFI>3V/m / EFT>1KV / ESD>4KV (contact)
IEC 60947-5-2,Part 7.4.1 / IEC 60947-5-2,Part 7.4.2
Stainless steel

EGS1-3016U-A3S2	11	EGS2-3025U-A3S2
EGS1-3016U-B3S2	12	EGS2-3025U-B3S2

5.8 φ3x0.5	
Approx.209 g	Approx.199 g

M 30	
●	○
16 mm	25 mm
stainless steel	
●	

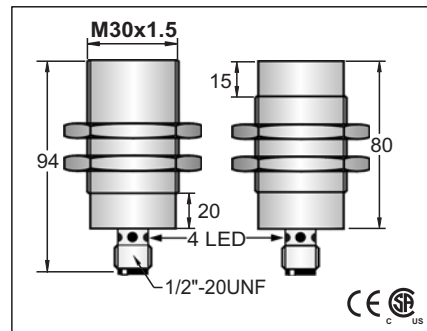

20-250 VAC, 50-60 Hz; 20-250 VDC
DC RIPPLE <10%
<2.5mA
200mA
<2.5mA
2.2A for 20ms
5mA
<=10 VAC : <=8 VDC
25HZ AC; 40 Hz DC
10ms/10ms
<15%(Sr)
<1.0% (Sr)
IP67
-25°C - +70°C
<10% (Sr)
YES
-
-
RFI>3V/m / EFT>1KV / ESD>4KV (contact)
IEC 60947-5-2,Part 7.4.1 / IEC 60947-5-2,Part 7.4.2
Stainless steel

EGS1-3016U-AUL3	56	EGS2-3025U-AUL3
EGS1-3016U-BUL3	56	EGS2-3025U-BUL3

5.8 φ3x0.5	
approx.147g	approx.137g

Note:

Coming Soon : Part numbers with underline  
 In Preparation: Part numbers with a line through the middle

